

3. EXTERNAL VIEW

3.1 Machine external view

Fig 3. 1 『External view (1) 』

S/N 4MBX0003~4MBX0033

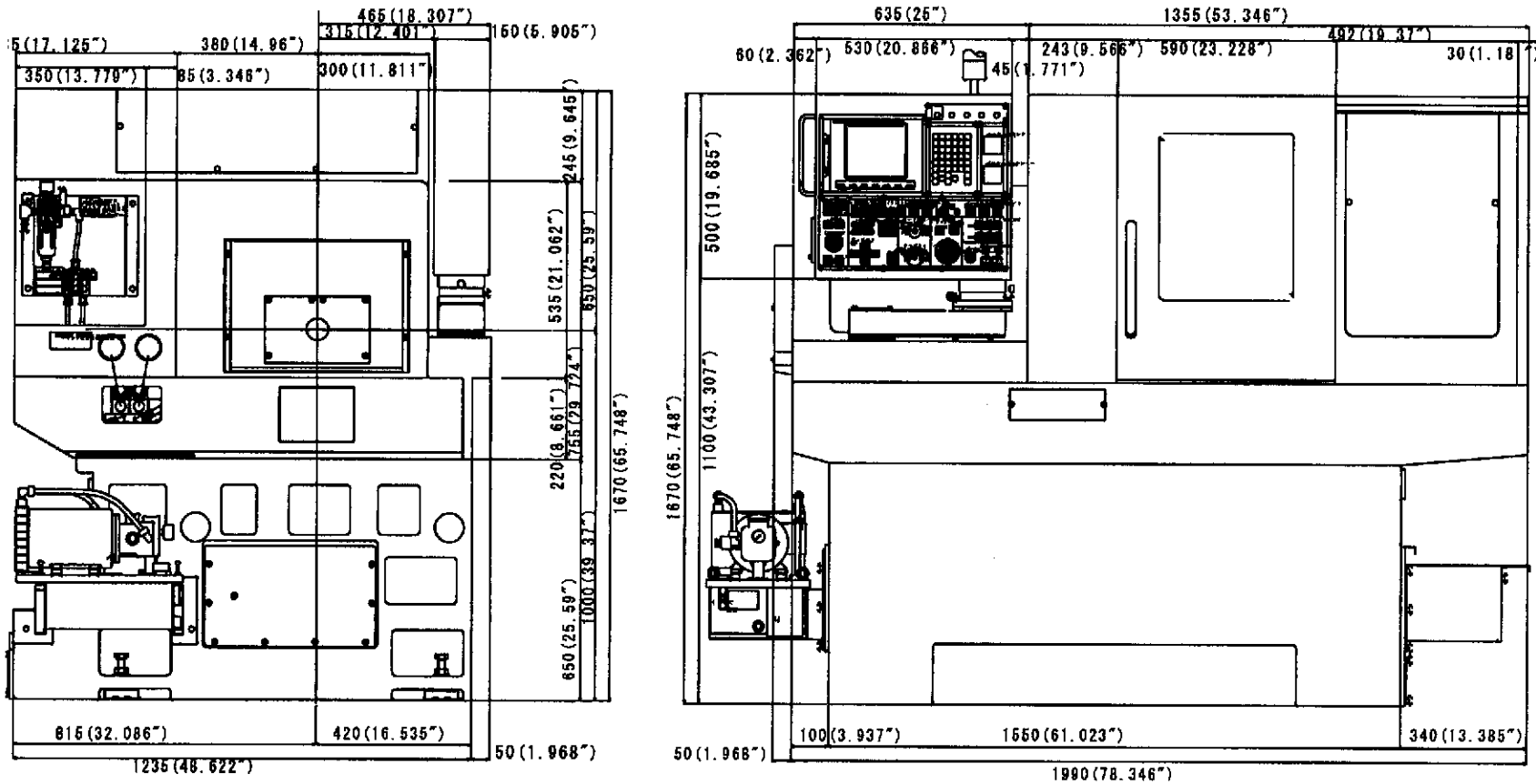

3. EXTERNAL VIEW

S/N 4MBX0084 -

3.1 Machine external view

Fig 3. 1 『External view (1) 』

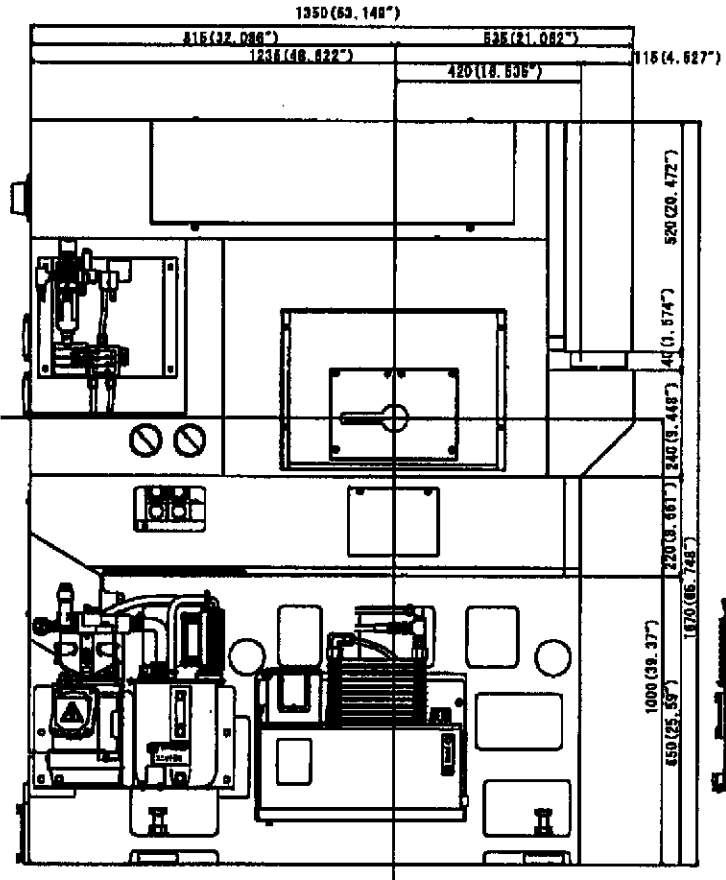
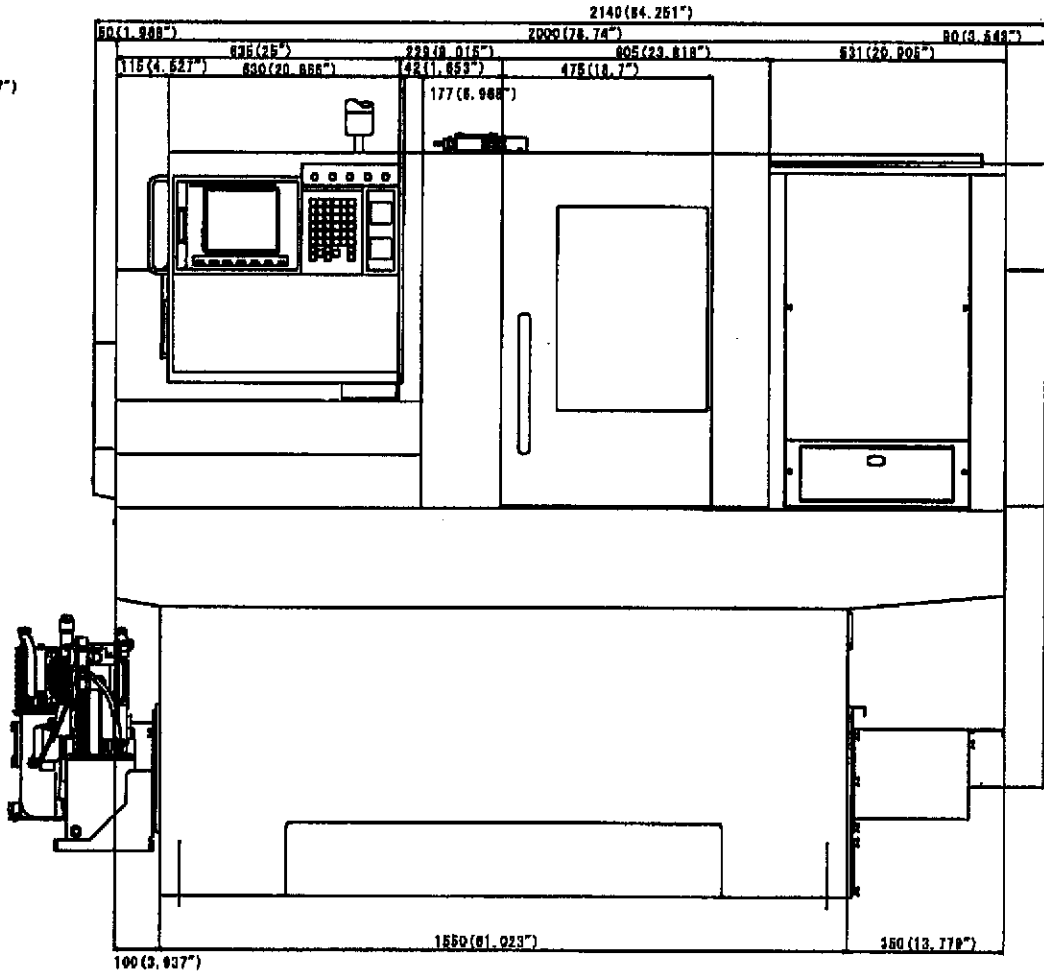
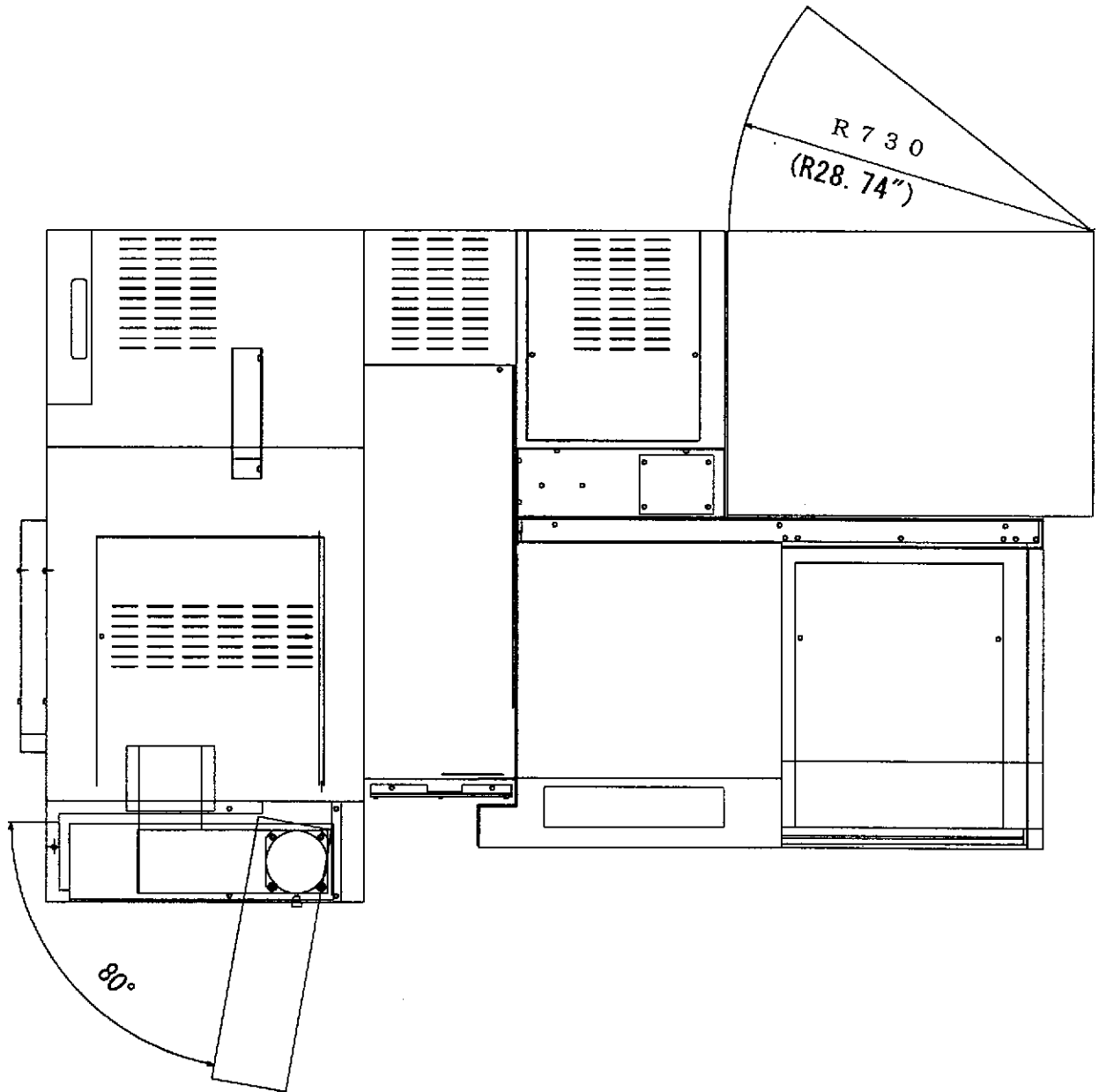
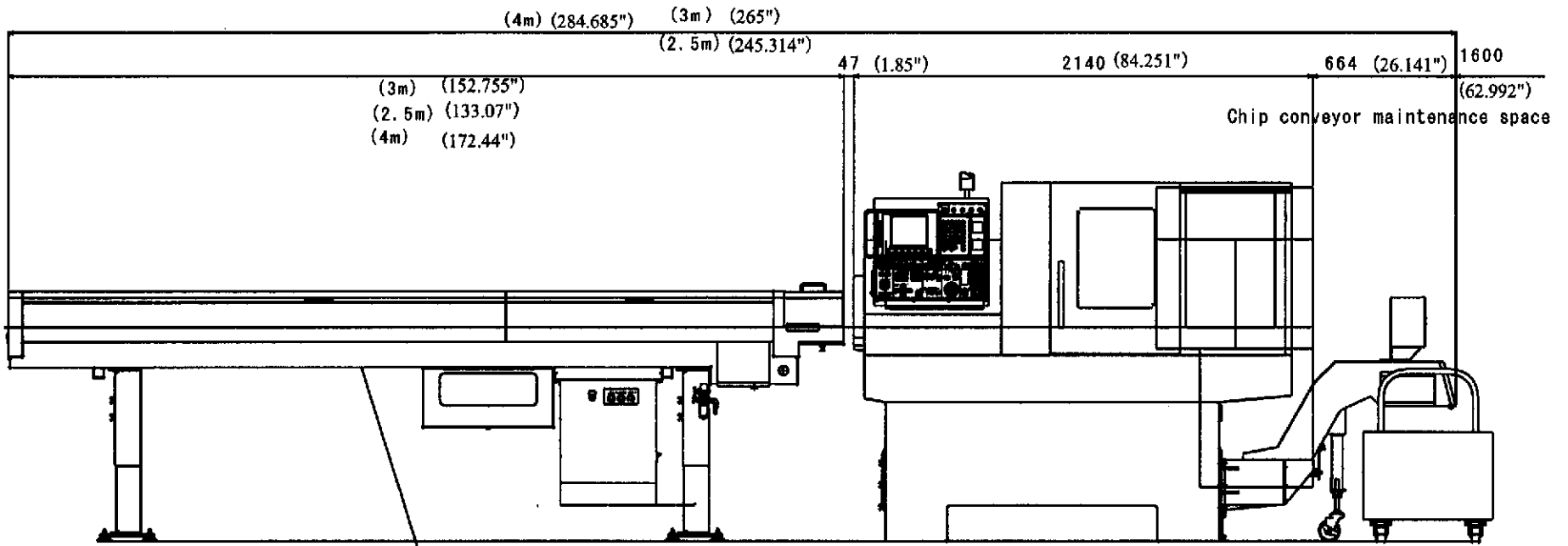

Fig 3. 1 (2) 『External view (2)』



3.2 Machine and ASR X-16Z external view



ASR X-16Z
ALPS TOOL

9. CONNECTING POWER SUPPLY TO THE MACHINE

9.1 Electrical power requirements

WARNING

Provide transformers individually as shown below to separate the power for electric welding machines, cranes, or other noise-generating machines from the power for Miyano CNC turning center.

Input power source



Electric welding machines, cranes, or other noise-generating machines

Only one Miyano CNC turning center
(Do not use transformer in common to other CNC machines)

NOTICE

Perform wiring of the ground wire and power cables in accordance with the regulations in your country.

Insufficient power capacity or insufficient power wire size can damage the machine.

These are the electrical power requirements:

Item	Requirements
Power source voltage & cycle	AC200/220V +5% -10%, 50/60Hz, 3Dia
Required power capacity	BX-20/26S : 20 KVA
Power cable	Insurated with rubber power line & sectional area over 14mm ²
Power source fuse or No-fuse breaker	Over 60A
Ground wire	Insurated with rubber cable & sectional area over 14mm ²

10. LUBRICATION

Supply oil to each section in accordance with lubrication and oiling list below.

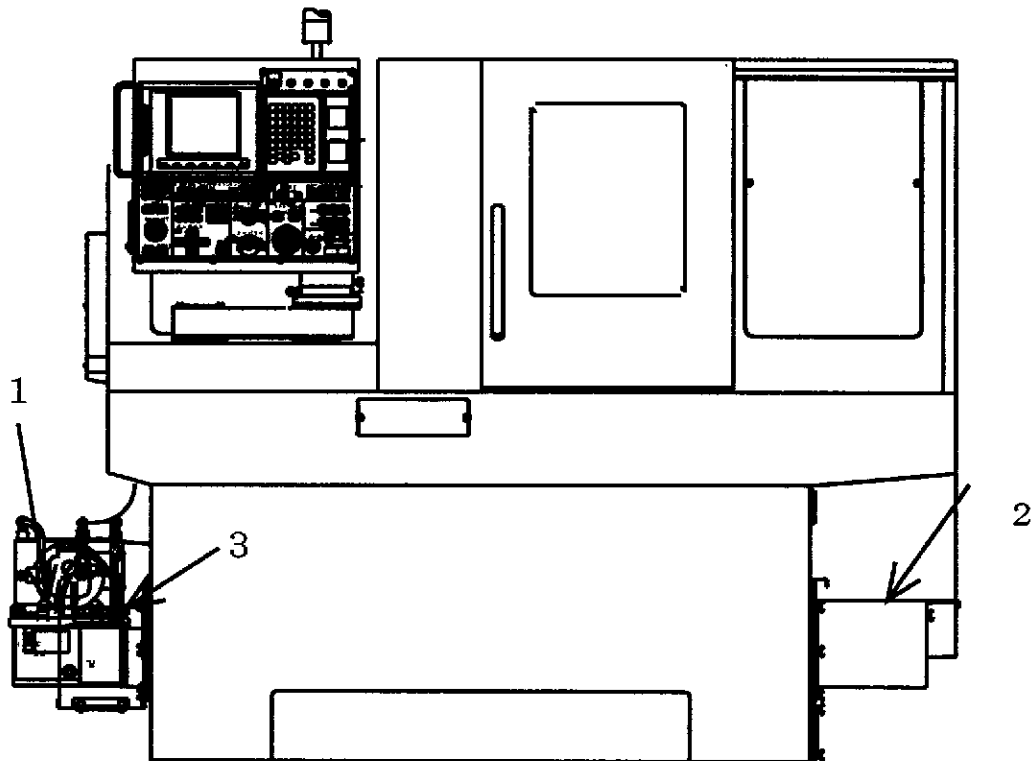

Fig.10 Place of oil supply

Table 10 Oil and grease supply

No.	1	2	3
Type of oil	Hydraulic oil	Coolant	Cooling oil
Place of oil supply	Hydraulic tank	Coolant tank	Cooling oil tank
Capacity	10 liter(2.64 Gal)	140 liter(36.9Gal)	8 liter(2.11Gal)
SHELL	TELLUS No.32	Refer to the maintenance manual.	VG2 MOBIL VELOCITY OIL No.3
MOBIL	DTE 24		
ESSO	NUTO H32		
EXXON	TERESSTIC No.32		

1. GENERAL LAYOUT OF MACHINE CONSTRUCTION

1.1 Layout of main components and their names

No.	Unit name	
1	Frame	
2	Spindle No.1 slide(Z1-axis)	
3	Spindle No.2 slide(X2-axis+Z2-axis)	
4	Slide unit No.1 (X1-axis+Y1-axis)	
5	Slide unit No.2 (Y2-axis)	
6	Hydraulic unit	
7	Pneumatic	
8	NC box	Electrical equipment
9	Control box	
10	Part conveyor	
11	Chip conveyor	
12	Cooling device	

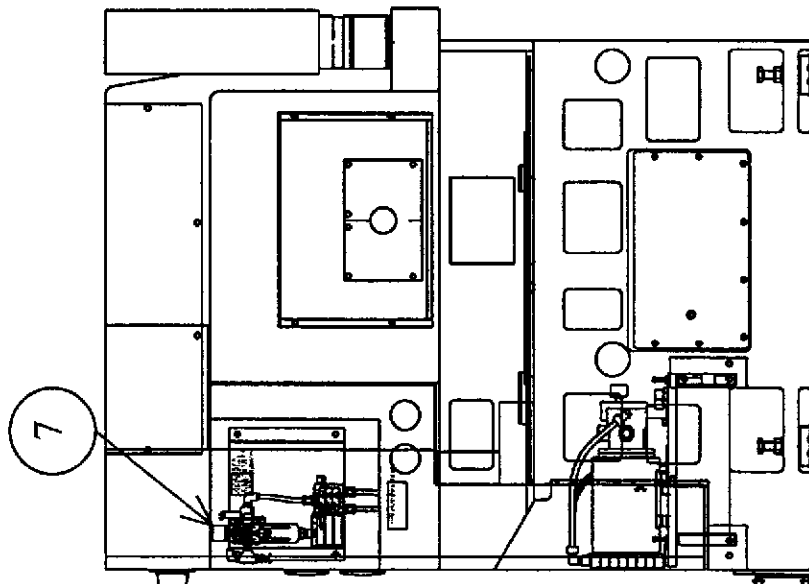
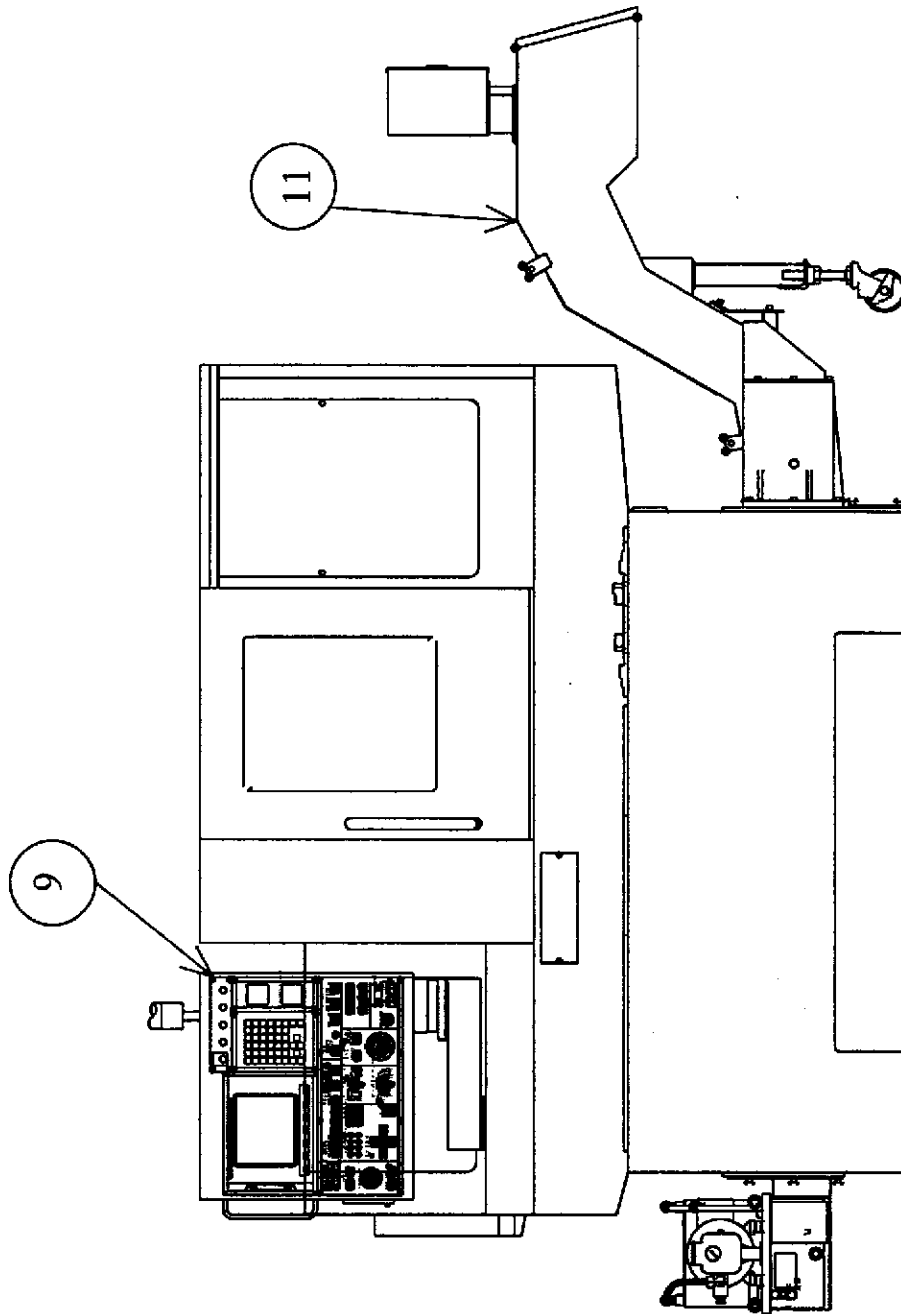

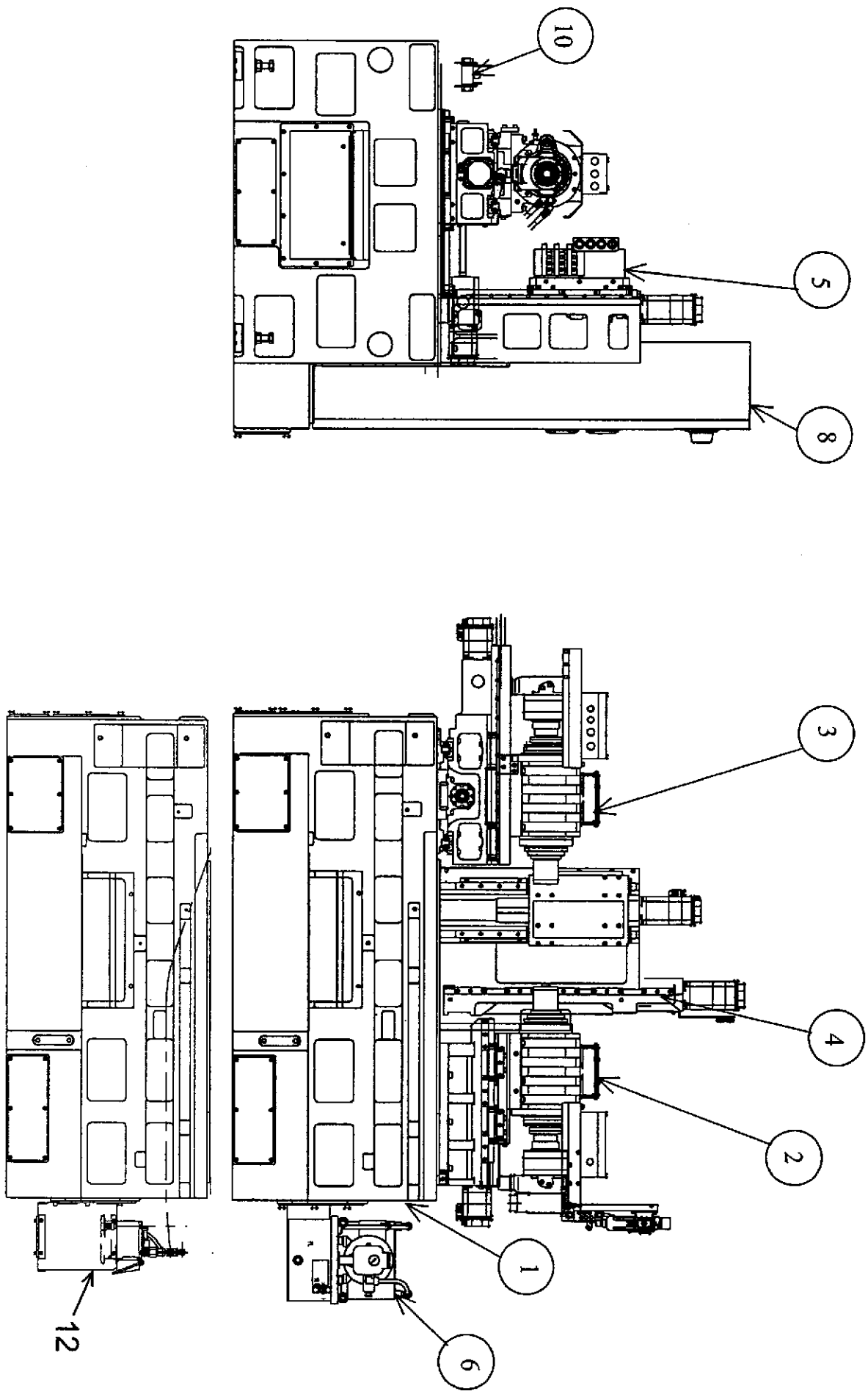

2. Specifications and technical data

2.1 Machine specificationse

() Inside is the specification of 20.

Specification item		Unit	BX-20S	BX-26S	
Processing capacity	Maximum blank diameter	mm	φ 20	φ 26	
	Maximum work length	mm	67(MAX250)		
	Between the spindle center	mm	330		
Machine composition	Bed form		Flat		
Principal axis	The number of spindle		2		
	Rotation speed	L-SP	min-1	80-8000	
		R-SP	min-1	80-8000	
	Inner diameter of draw tube	L-SP	mm	φ 28	
		R-SP	mm	φ 28	
Tool slide	The number of tool slides		2		
	The type of tool slide	Slide unit No1		Linear turret	
		Slide unit No2		Linear turret	
	Attachment number	Tool total	Slide No1	Number	18
		(Revolving tool)	Slide No2	Number	7
		LSP tool	Slide No1	Number	6
		RSP tool	Slide No2	Number	3
		LSP plane tool	Slide No1	Number	4
		RSP plane tool	Slide No2	Number	4
	Tool size	Slide No1		mm	□16
		Slide No2		mm	□16
		Slide No1		mm	φ 20
		Slide No2		mm	φ 20
	Machine capacity	L-SP drilling		mm	φ 12
		L-SP tapping		mm	M8
		L-SP drilling		mm	φ 12
		L-SP tapping		mm	M8
The chuck sleeve			AR-16		
Revolving tool	Attachment number	Slide unit No1		Number	X 4+Z 2+2=8
		Slide unit No2		Number	
	Capability	Slide unit No1	Drill	mm	φ 8
			Tap	mm	M6
			Spindle speed	min-1	100-4000
			The chuck sleeve		AR-16
The amount of movements	Slide No1	X1	mm	135	
		Y1	mm	260	
		L-SP	Z1	mm	70
		Slide No2	Y2	mm	215
			R-SP	X2	mm
		Z2	mm	238	
	Rapid-traverse speed	Slide No1	X1	m/min	24
			Y1	m/min	24
		L-SP	Z1	m/min	24
			Slide No2	Y2	m/min
		R-SP		X2	m/min
		Z2	m/min	24	
Thrust	Slide No1	X1	N	1847	
		Y1	N	3325	
	L-SP	Z1	N	1847	
		Slide No2	Y2	N	3325
	R-SP		X2	N	1847
	Z2	N	1847		

S/N 4MBX0003 - 4MBX0083

Specification item				Unit	BX-20S	BX-26S	
Electric motor	Spindle motor	L-SP		KW	3.7/2.2		
		R-SP		KW	3.7/2.2		
	Slide	Slide No1	X1	KW	0.5		
			Y1	KW	0.75		
		L-SP		Z1	KW	0.5	
		Slide No2	Y2	KW	0.75		
			R-SP	X2	KW	0.5	
		Z2		KW	0.5		
	Revolving tool	Slide unit No1		KW	0.5		
				KW	0.5		
	Hydraulic operating motor			KW	0.75		
Coolant pump motor			KW	0.25			
High pressure coolant pump			KW	0.821/1.349(50Hz/60Hz)			
Tank capacity	Hydraulic tank capacity			L	10		
	Coolant tank capacity			L	140		
of business ele	Power supply capacity			KVA	20		
	Power supply voltage			V	AC200/220		
	Power supply frequency			Hz	50/60		
	Source pressure of air pressure			Mpa	0.5		
	Fuse capacity			A	60		
achine capacit	Spindle center			mm	1000		
	Height of a machine			mm	1670		
	Floor space		Width	mm	2140		
			Depth	mm	1235		
	Machine weight			Kg	3000		
NC equipment	Maker				FANUC		
	Type				18i-TB		

S/N 4MBX0084 -

Specification item			Unit	BX-20S	BX-26S	
Electric motor	Spindle motor	L-SP	KW	3.7/2.2		
		R-SP	KW	3.7/2.2		
	Slide	Slide No1	X1	KW	0.5	
			Y1	KW	0.75	
		L-SP	Z1	KW	0.5	
		Slide No2	Y2	KW	0.75	
			X2	KW	0.5	
		R-SP	Z2	KW	0.5	
	Revolving tool	Slide unit No1		KW	0.5	
				KW	0.5	
	Hydraulic operating motor			KW	0.75	
Coolant pump motor			KW	0.25		
High pressure coolant pump			KW	0.821/1.349(50Hz/60Hz)		
Tank capacity	Hydraulic tank capacity		L	10		
	Coolant tank capacity		L	140		
of business ele	Power supply capacity		KVA	20		
	Power supply voltage		V	AC200/220		
	Power supply frequency		Hz	50/60		
	Source pressure of air pressure		Mpa	0.5		
	Fuse capacity		A	60		
achine capacit	Spindle center		mm	1000(39.37")		
	Height of a machine		mm	1670(65.74")		
	Floor space	Width	mm	2140(84.251")		
		Depth	mm	1350(53.149")		
Machine weight		Kg	3000			
NC equipment	Maker			FANUC		
	Type			18i-TB		

2.2 Specifications of the NC (MIYANO-FANUC 18i-TB)

	Metric	Inch
Axis controlled Cs axis control	6(8)axes : 1 system: X1, Z1, Y1, (C1) 2 system: X2, Z2, Y2, (C2) 4 axis are controlled simultaneously	
Input command Min. input increment Min. output resolution Maximum input value Absolute Incremental Decimal point programming Inch/metric input Tape code	0.001mm X1-axis:0.0005mm Z1,Z2,Y-axes: 0.001mm ±99999.999mm X1, Z1, Y1, C1 and U, W, H and V	0.0001in. X1-axis:0.00005in. Z1,Z2,Yaxes: 0.0001in.
Interpolation functions Positioning Linear interpolation and cornering Circular interpolation	G00 G01 G02/G03 (Clockwise/Counterclockwise)	
Feed rate Feed per revolution Feed per minute Dwell Feed rate per minute/Feed rate per revolution Thread cutting Variable lead thread cutting Handle Automatic acceleration/deceleration Feed rate override Rapid feed override	F3.4 mm/rev F6 mm/min G04 G98/G99 G32 F command G32 Manual pulse generator (0.001/01 per graduation) 0 ~ 150% (every 10%) (F0.25%, 50%, 100%)	
Part program storage and editing Part program storage Additional part program storage Editing operation Program number search Sequence number search Address search	20m in tape length 40,80,160m in tape length(total) Alter,Insert and Delete	
Operation panel and display screen Display screen: Operation panel: Display items: MDI	9.5 in. CRT display Flat keys board Present position, commands, offset, parameter, etc.	
Input/Output device Input/output interface External data input	RS-232-C External tool compensation External message function	

	Metric	Inch
External data input External work number search	External key input External program number search 1 ~ 15	
S, T, M-Function Spindle speed function(S-function) Constant surface speed control Tool function (T-function) Miscellaneous (M-function)	S5-digit command(G97) G96 T4-digit command (First 2-digits:Tool number and geometry offset number) (Second 2-digits:Wear offset number) M3-digit command	
Tool function Geometry offset Wear offset Offset pairs Tool nose radius compensation	Command first 2-digits Command last 2-digits 32 pairs G41, G42,G40	
Program input Manual reference position return Automatic return to reference point Reference point return check Automatic coordinate system setting Coordinate system setting	G28 G27 G50	
Operation support function Single block Optional stop Optional block skip Dry run Machine lock		
Program support function Circular interpolation by R programming Tool nose radius compensation Chamfering and corner radius Canned cycles Multiple repetitive cycles Sub-program Custom macro B Programmable data input	G90, G92, G94 G70 ~ G76 G10	
Mechanical precision offset support Backlash compensation		
Machine support function Self-contained PMC Axis interlock		

	Metric	Inch
Safety and maintenance Emergency stop Over travel Stored stroke limit Self-diagnosis Splashguard interlock	Alarm display, Diagnosis of input/output signals	
Environmental conditions	Ambient temperature: 0 ~ 45° Humidity: 75% relative humidity or less Vibration: 0.5G or less	
Servo systems Servo motor Servo amplifier Position detector	AC digital servo motor Transistor PWM control system Pulse encoder	
Others Run hour/piece counter display Back ground editing Graphic display Continuous thread cutting Clock display Custom macro B Direct drawing dimension input		

ツ ー リ ン グ

TOOLING

1.2 The tooling at the time of a standard shaft

Standard Type

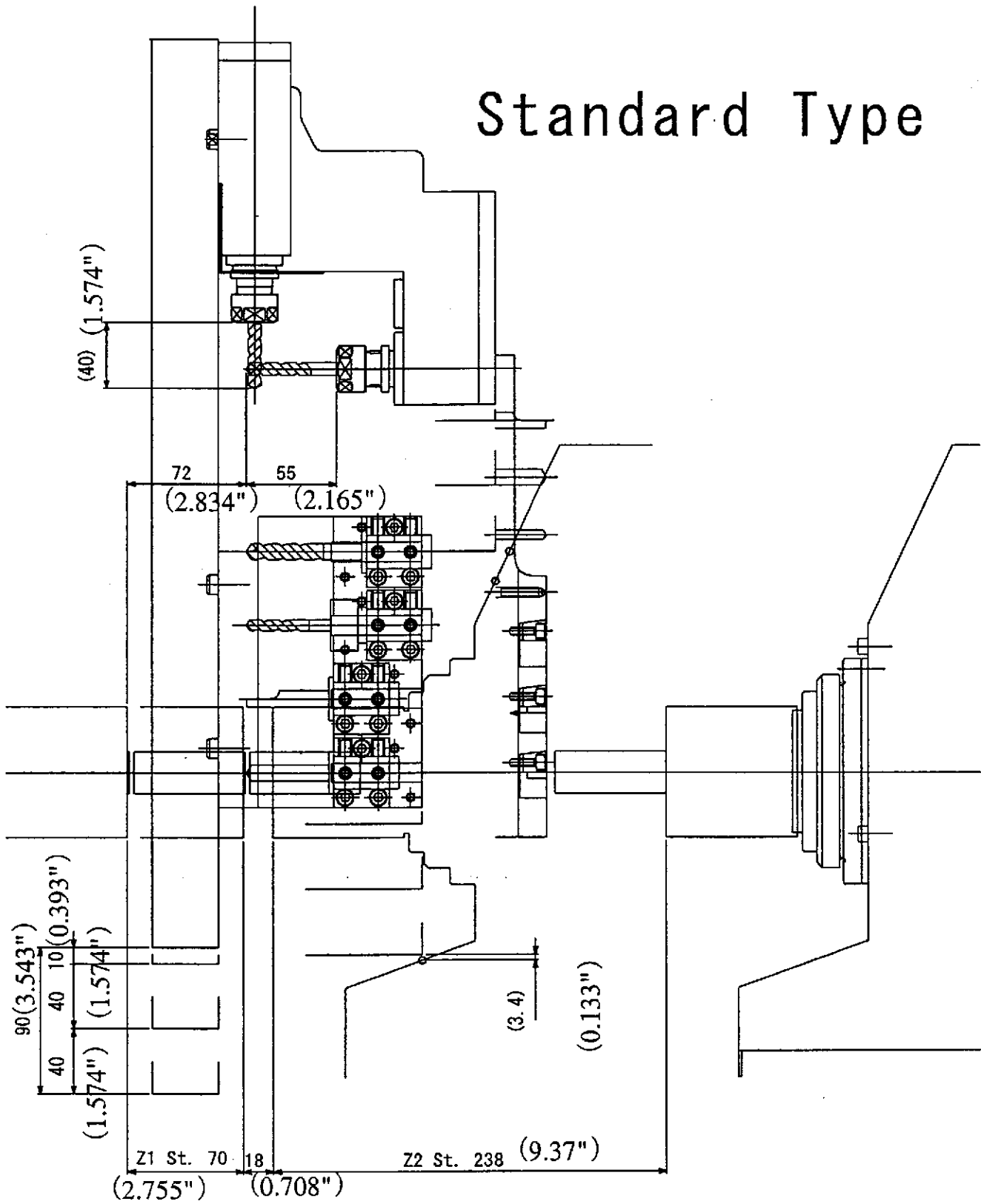

1.3 The tooling at the time of a long shaft

Long Shaft Type

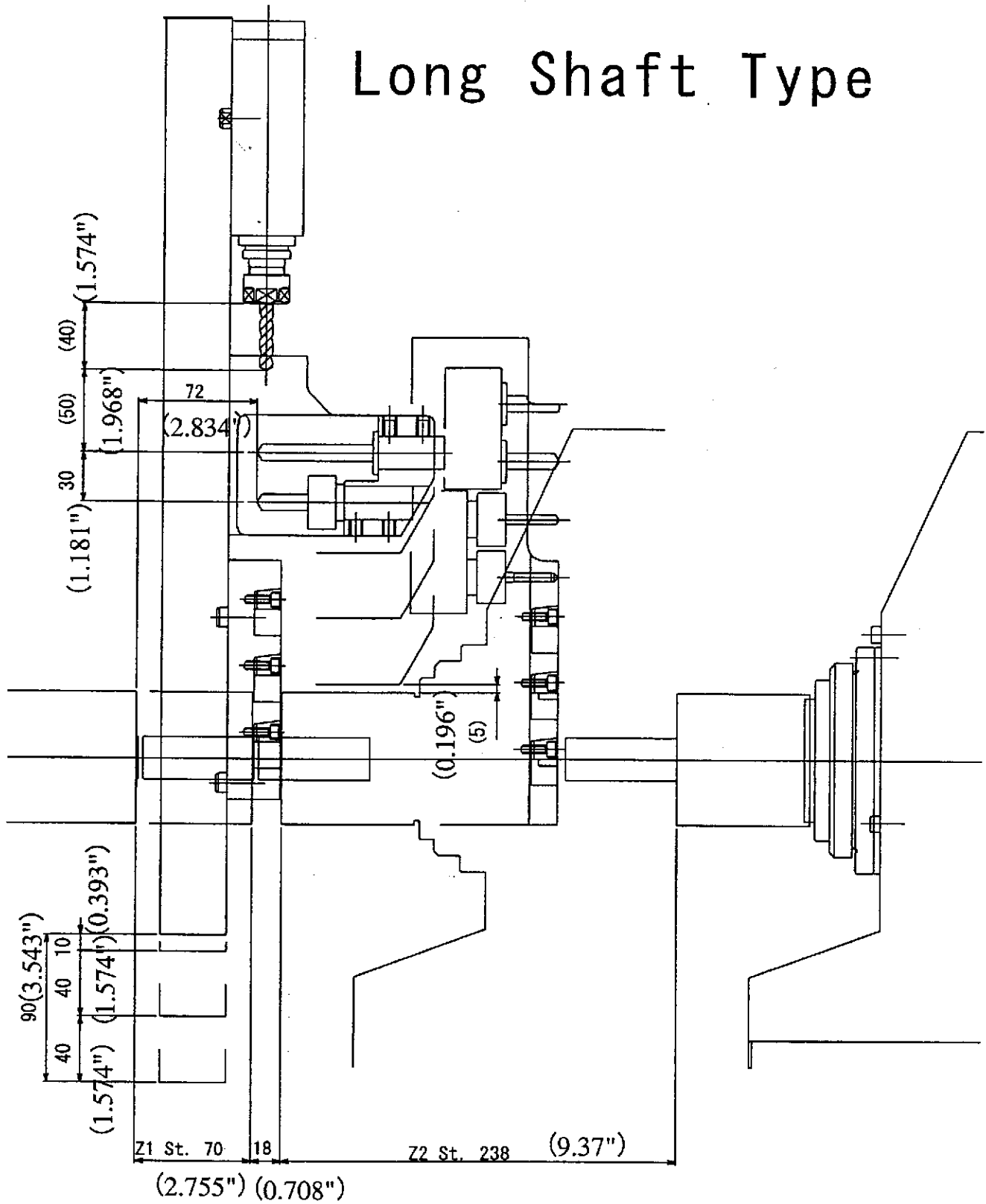

ツール システム図

SLIDE UNIT No.1

4M730001
TURNING TOOL HOLDER No.1 A

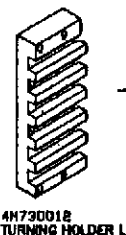

4M730012
TURNING HOLDER L

4M731000
TURNING TOOL HOLDER No.1 B



4M731010
TURNING HOLDER S

4M737000
PLANE HEAD No.1 A

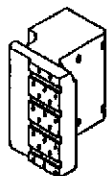

4M737010
PLANE HOLDER M

4M738000
PLANE HEAD No.1 B

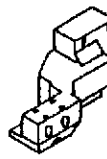

4M738030
PLANE HOLDER B-R

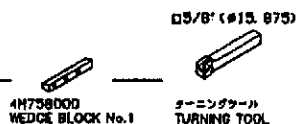

4M738000
WEDGE BLOCK No.1

ターニングツール
TURNING TOOL

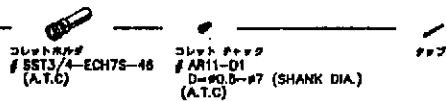

コレット #1
SST3/4-ECH75-46
(A.T.C)

コレット #2
AR11-D1
D=φ0.8-φ7 (SHANK DIA.)
(A.T.C)

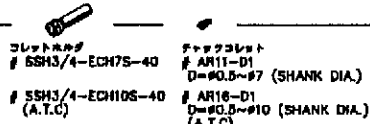

コレット #3
SSH3/4-ECH75-40
(A.T.C)

タップコレット
AR11-D1
D=φ0.8-φ7 (SHANK DIA.)
AR16-D1
D=φ0.8-φ10 (SHANK DIA.)
(A.T.C)

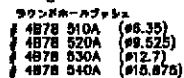

タップドリル
4B78 510A (φ6.35)
4B78 520A (φ8.525)
4B78 530A (φ12.7)
4B78 540A (φ15.875)

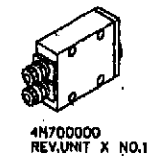

4M700000
REV.UNIT X NO.1

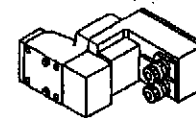

4M701000
REV.UNIT Z NO.1M

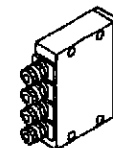

4M707000
REV.UNIT X NO.1 W

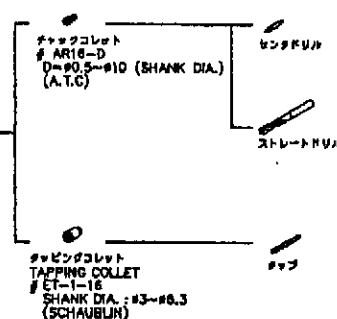

タップコレット
AR16-D
D=φ0.8-φ10 (SHANK DIA.)
(A.T.C)

タップコレット
CT-1-16
SHANK DIA.: φ3-φ6.3
(SCHAUBLIN)

SLIDE UNIT No.2

4M746002
PLANE &
TURNING TOOL HOLDER No.2

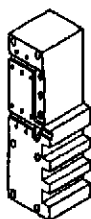

4M746012
TOOL HOLDER No.2

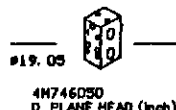

4M746050
D. PLANE HEAD (inch)

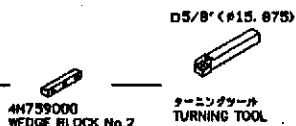

4M739000
WEDGE BLOCK No.2

ターニングツール
TURNING TOOL

2. TOOLING SYSTEM

S/N 4MBX0097 -

SLIDE UNIT No.1

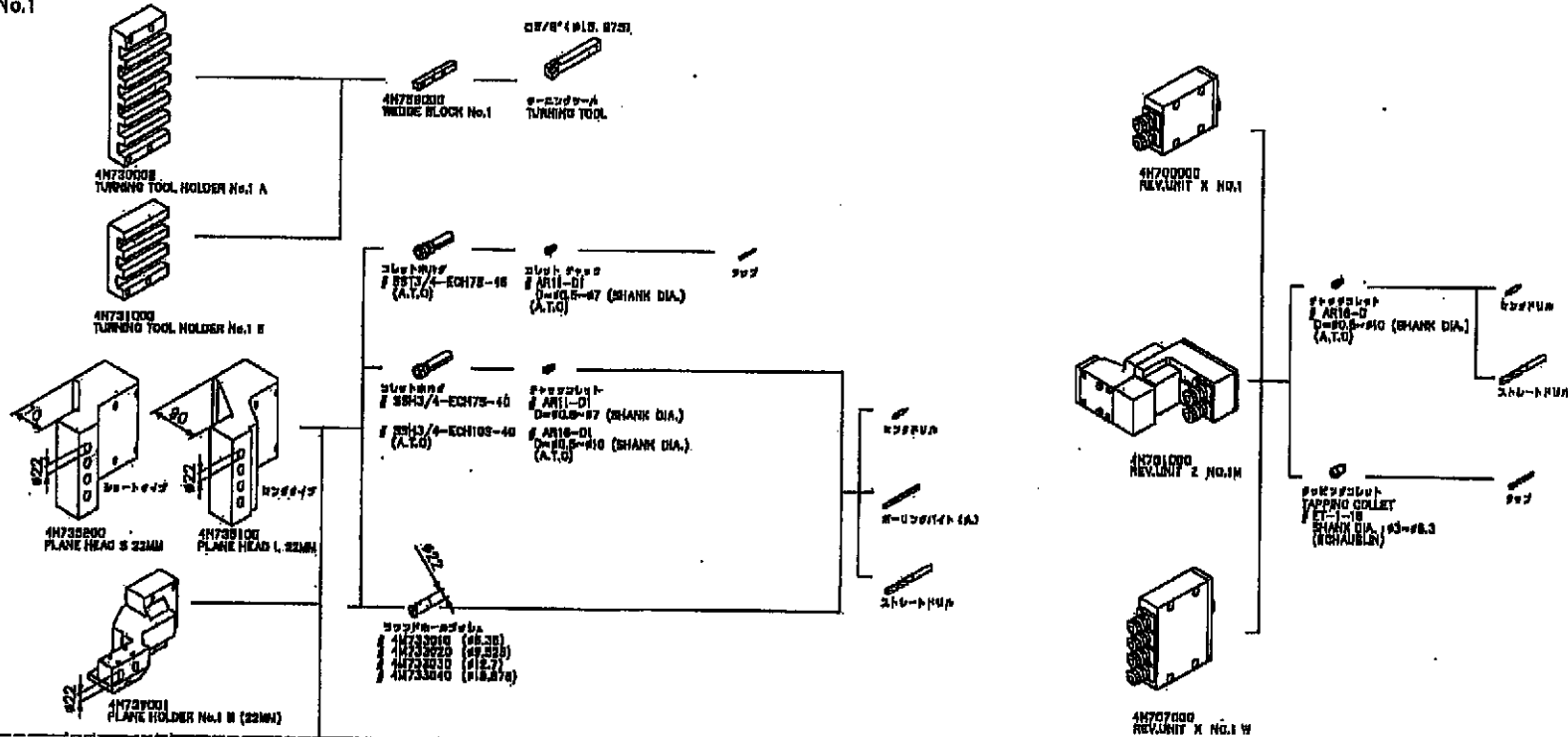

SLIDE UNIT No.2

